

N·E·A·R®

High-Output, Long-Throw Loudspeaker

Model A12



Features

- High-powered, all-weather speaker
- Specially designed vent covers help keep water out
- High efficiency and power handling for optimal performance
- One model for both 70V and low-impedance systems
- 225W at 16 ohms
- 70V Power settings: 128, 64, 32, 16, 8 watts
- Dual 6.5" metal-alloy MDT™ mid/bass speaker cones are extremely stable in all environments
- Patented MLS™ Ferrofluid voice coil suspension replaces distortion-causing mechanical spider
- Horn-loaded, 1" exit compression driver features a 1.9" Mylar diaphragm for consistent long-term performance
- 90° Horn delivers constant coverage over listening area
- Dual-layer voice coil with separate inner and outer windings for high output and ultra-low distortion
- Advanced polymer compound surrounds resist UV rays, chemicals, and salt spray
- Gold-plated, rust-proof input connectors
- High-density, injection-molded cabinet resists chipping and scratching
- Low-resonance cabinet structure
- Heavy-gauge stainless steel mounting yoke with 180° swivel
- Easy-to-grip, oversized mounting knobs
- Speaker mounts with knobs attached for easier, safer installation in hard-to-reach locations
- Adjustable Tilt-Mount Adapter attaches to mounting yoke (Model TMA812, sold separately)
- Corrosion-resistant woofer frames and mounting hardware for long-lasting, like-new appearance
- Black cabinet color; attractive styling using patented Armadillo ridges that improve durability as well as sound

Description

The A12 features NEAR's unique technologies to produce the highest sound quality in the most durable and reliable loudspeakers available. The A12 is a compact, high-powered speaker that projects well in open spaces like theme parks, sports fields, and plazas.

Precise sound reproduction is achieved with two 6.5" mid-bass drivers employing both MDT and patented MLS technologies for superior sound and weather resistance. The high-frequency driver is a 1.9" horn-loaded diaphragm. A built-in transformer makes the A12 compatible with 70V sound systems. The transformer can be easily bypassed for use in low-impedance systems (16 ohms). NEAR's patented spiderless technology (MLS™) and advanced materials deliver out-of-the-box performance year after year. Speaker diaphragms are manufactured with materials that will not be altered by constant exposure to UV rays or water, cold or heat, or extremely high or low humidity.

Unique MDT™ (Metal Diaphragm Technology):

- High rigidity and low mass of metal versus traditional papers and plastics
- Extremely stable cone structure over long periods of time
- Fast transmission of sound through the diaphragm means low energy storage
- Special anodizing process creates a ceramic coating for increased stiffness
- Efficient heat-sinking of voice coils under long-term, high-power situations

Patented MLS™ (Magnetic Liquid Suspension):

- Voice coil is constantly centered for lower distortion
- Voice coil is more efficiently heat-sunked by fluid instead of air
- Greater linearity is accomplished because the mechanical spider is eliminated
- Constant lubrication of the gap prevents oxidation from outdoor use

Technical Specifications

SPECIFICATIONS	A12
Frequency Response (-10 dB)*	55 Hz to 17.5 kHz
LF Driver	Dual Metal-Composite 6.5" Cone Woofers, Patented MLS Voice Coil Guidance System
HF Driver	Weatherproof 1.9" Mylar Diaphragm Constant Directivity Horn, 1" Exit
Sensitivity (1W/1M)	94.5 dBspl
Dispersion	90° Horizontal, 45° Vertical
Impedance Ratings	Low (16 ohms) / High (70V)
Power Input (Max.)	225W @ 16 ohms; 128W @ 70V
Power Settings (in watts)	70V: 128, 64, 32, 16, 8
Grille Material	Perforated Polypropylene
Cabinet Material	Black, Mineral-filled Polypropylene, with UV Inhibitor
Terminations	Dual 4-Terminal Barrier Strips with Gold-plated, Rust-proof Screws
Product Weight	22 lb.
Speaker Dimensions	10-1/4" W x 17-7/8" H x 11-3/4" D
Included Accessories	Color-matched, Stainless Steel Mounting Bracket
Optional Accessories	Adjustable Tilt-Mount Adapter (Model TMA812)
Environmental	Meets or Exceeds Mil-Std-810E

* Half-space response, 16-ohm input

Architect & Engineer Specifications

The loudspeaker shall be a NEAR Model A12 with a power handling capacity of 225W (16-ohm) or 128W (70V) or approved equivalent. The loudspeaker shall consist of two 6.5" nominal low-frequency transducers and one 1.9" nominal mylar high-frequency transducer with a filter network for dividing and smoothing frequencies between the transducers. A mathematically-aligned, vented enclosure shall house all components. All vents shall be further protected from water ingress by acoustically transparent fabric designed to shed water. The enclosure shall be constructed from an injection-molded, high-density (30% or greater) mineral-filled polypropylene material compounded with UV inhibitors.

Enclosure shall be molded in black. Surface shall be able to accept paint. Perforated speaker grilles shall be made from color-matched perforated polypropylene, also able to accept paint if required.

The low-frequency drivers shall utilize a metal-alloy cone with deep-anodized surface treatment for rigidity and corrosion resistance. The cone shall provide a heat transfer thermal path for the voice coil under high-power inputs. Compounded rubber cone surrounds shall be formulated to withstand all-environment installations, including salt spray, ultraviolet light (UV), chlorine exposure, heat, cold, and constant humidity. The voice coil will be centered via a high-gauss, low-viscosity magnetic fluid (Ferrofluid), which increases the heat transfer rate from the voice coil under long-term high-power use. The magnetic fluid shall prevent corrosion from occurring in the magnet gap.

The high-frequency driver shall utilize an environmentally stable Mylar diaphragm. An integrated horn and phase compensation device shall provide increased output sensitivity and controlled coverage of the output.

Environmental testing shall ensure long-term operation in all weather. Specifications shall exceed Mil-Std-810E Test Methods for Temperature, Humidity, Ultra-Violet Light, and Salt Spray. In addition, IEC529 Ratings shall classify the speaker as an IP66 level (protection against dust and powerful jets of water from any direction).

The mounting yoke provided with the speaker shall be designed with a built-in angle to facilitate installation when downward angulation is required, as well as 180-degree left-to-right adjustment. The yoke shall be formed from heavy-gauge stainless steel (minimum 3mm thick), and finished with a scratch-resistant paint. In addition, an optional Adjustable Tilt-Mount Adapter (Model TMA812) shall be available which provides additional angles for precise orientation vertically over 18 specified points.

The input connectors for 16-ohm and 70-volt systems shall be gold-plated, rust-proof screws with integral clamping washers.

Dimensions of the loudspeaker shall not exceed 10-1/4" W x 17-7/8" H x 11-3/4" D. Weight shall not exceed 22 lb.

Mechanical Drawings

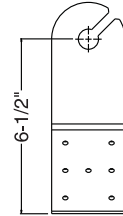
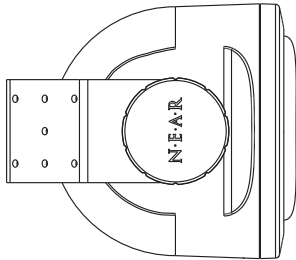
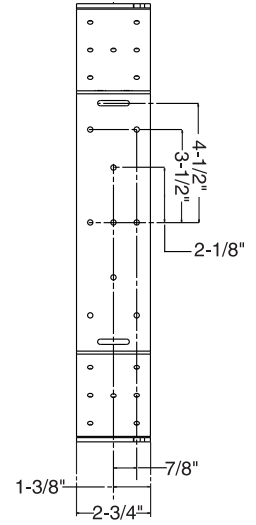
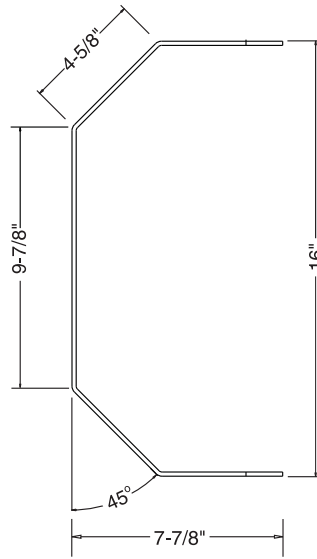
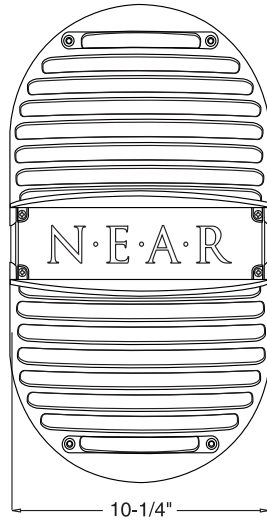
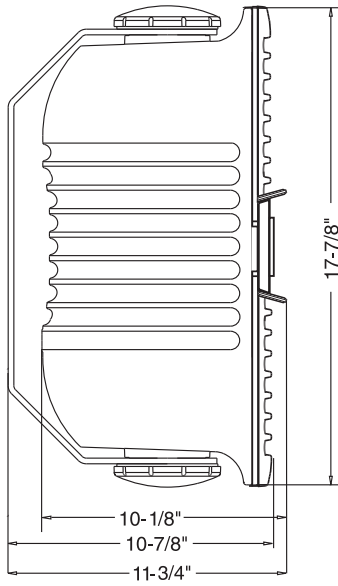

BOGEN®
COMMUNICATIONS, INC.

50 Spring Street, Ramsey, New Jersey 07446, USA
201-934-8500 FAX: 201-934-9832
www.bogen.com